

## P/N OE2B7/26117SSI

Diaphragm pump in aluminum and polypropylene series APPB-1 with dual inlet, 1" flanges, membranes and balls in Santoprene™ and seats in AISI 316 stainless steel

### SECTORS OF USE

Agriculture, Automotive, Building and road construction, Industry, Lube trucks and transports

### FEATURES

Ratio	1:1
Flow rate	170 l/min
Max pressure	8 bar
Max cycles per minute	300 cpm
Delivery per cycles	0,590 l
Max suction lift	dry column 5 m - wet column 7,5 m
Max size pumpable solids	3 mm
Max working temperature	65 °C
Noise level	75 dB
Max air consumption	1,60 m <sup>3</sup> /min
Air working pressure	2÷6 bar
Air inlet connection	G 3/8" (f)
Air outlet connection (muffler)	G 1/2" (f)
Fluid inlet connection	dual inlet ANSI 150 - DIN PN 10 - JIS 10K 1" (25 mm) proneness to G 1.1/4" (f) thread



### OVERALL DIMENSIONS (mm)

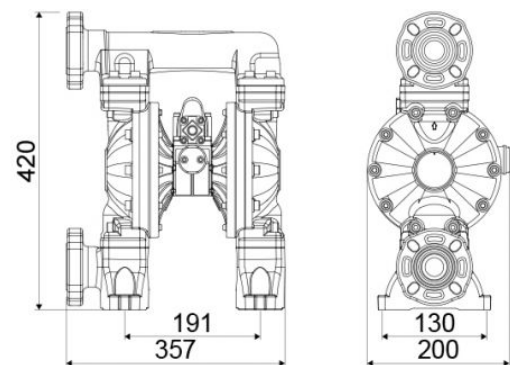

Fluid outlet connection	ANSI 150 - DIN PN 10 - JIS 10K 1" (25 mm) proneness to G 1.1/4" (f) thread
Balls for inlet	ball valve
Membranes	Santoprene™
Balls	Santoprene™
Seats	AISI 316 stainless steel
Packing	No. 1 - 0,030 m <sup>3</sup>
Gross weight	12,1 kg