

P/N 0E3C3/50111TTP



Diaphragm pump in aluminum series AAB-2 with multi ported inlet/outlet, membranes and balls in Teflon® and seats in polypropylene

SECTORS OF USE

Agriculture, Automotive, Building and road construction, Industry, Mining, Lube trucks and transports

FEATURES

Ratio	1:1
Flow rate	570 l/min
Max pressure	8 bar
Max cycles per minute	147 cpm
Delivery per cycles	4,150 l
Max suction lift	dry column 5 m - wet column 7,5 m
Max size pumpable solids	6,5 mm
Max working temperature	100 °C
Noise level	82 dB
Max air consumption	4 m ³ /min
Air working pressure	2÷6 bar
Air inlet connection	G 3/4" (f)
Air outlet connection (muffler)	G 1" (f)
Fluid inlet connection	G 2.1/2" (f)
Fluid outlet connection	G 2" (f)
Balls for inlet	ball valve



OVERALL DIMENSIONS (mm)

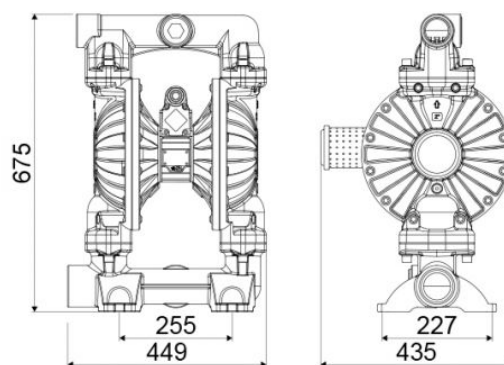

Membranes	Teflon® + Hytrel®
Balls	Teflon®
Seats	polypropylene
Packing	No. 1 - 0,120 m ³
Gross weight	45 kg